

Condansate Pumps FCP Series

Steam Powered Condansate Recovery

Description



Description

The transport and recovery of condensate for reuse always requires a positive pressure differential from the source to the destination. In some instances, a trap's inlet steam pressure may be sufficient to overcome system backpressure, but in many installations the differential pressure is negative and requires a pump to transfer condensate to a recovery area.

Advantages

1. FCP is not mechanical pump with float. FCP includes level gauges (electronic or tubetype) and this level gauge controls the pump condensation level.

2. It has less material to break or maintenance such as float and lever arm. When condensation reaches to high level, with the level gauge's signal, 3 way valve changes the flow direction and allow the steam for discharging condensate.

3. You can use FCP with steam or air. It does not require only steam.

Includes

- FCP Series Condansate Pump
- Level Control System
- Non-Return Disco Check Valves x 2
- Steam Selenoid Valves x 2
- Pressure Gauge
- Control Box



Note: All certification/inspection requirements must be stated at the time of order placement.

Condensate Pumps FCP Series

Steam Powered Condensate Recovery

Series Dimensional Data

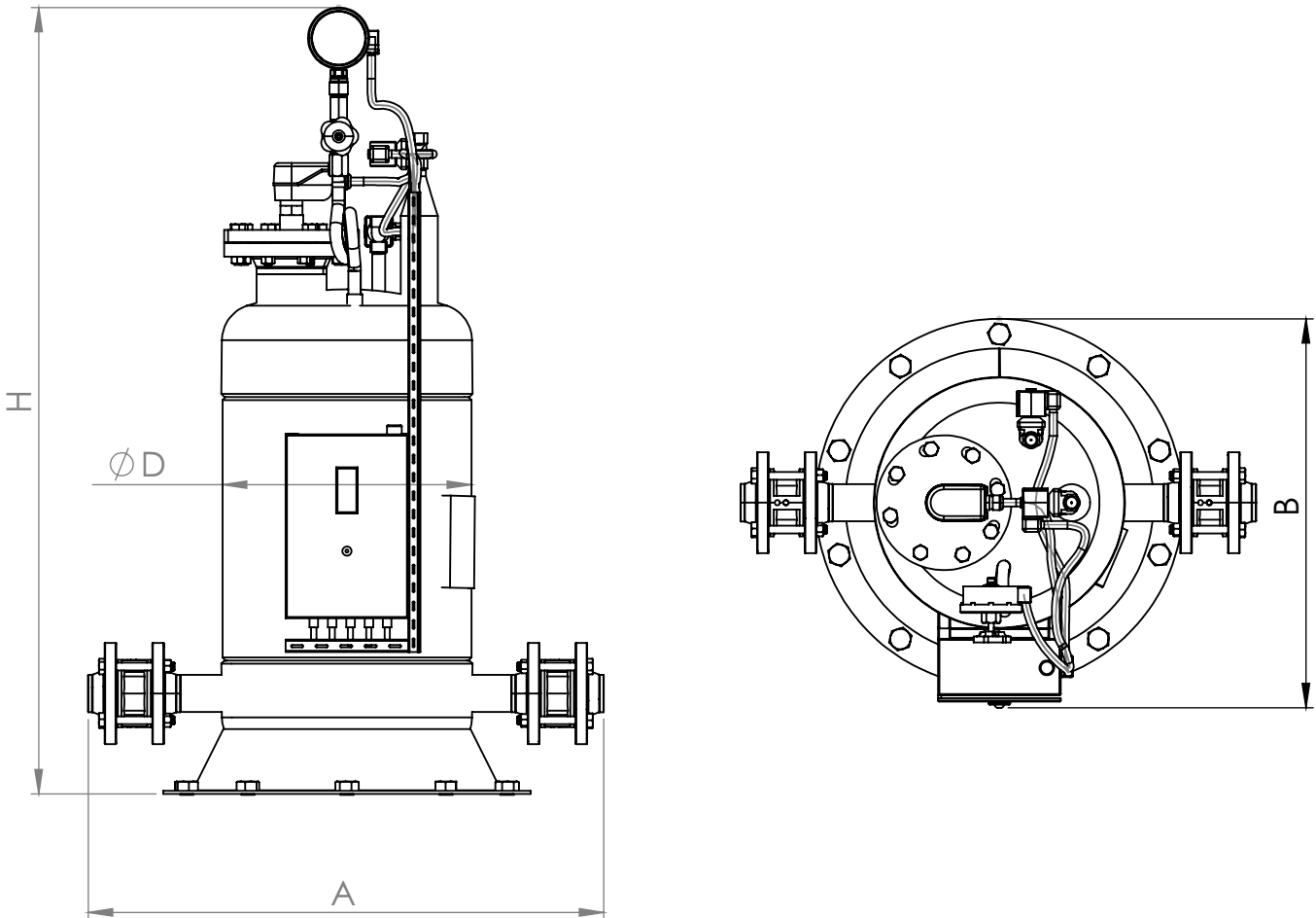

Technical Data

Type		FCP32	FCP40	FCP50	FCP65	FCP80
Capacity	t/h	1	2	5	7	10
Volume	l	30	50	100	200	400
Dimensions	A	595	712	842	970	1150
	B	418	510	635	728	882
	D	219	324	406	508	609
	H	912	1090	1284	1470	1685
Connections						
I - Condensate Inlet		DN32	DN40	DN50	DN65	DN80
II - Condensate Outlet		DN32	DN40	DN50	DN65	DN80
III - Motive Steam Inlet		1/2"	1/2"	3/4"	3/4"	1"
IV - Vent		1/2"	1/2"	3/4"	3/4"	1"